

Estd 1990

**KRSNA** Group  
CONCEPT TO REALITY

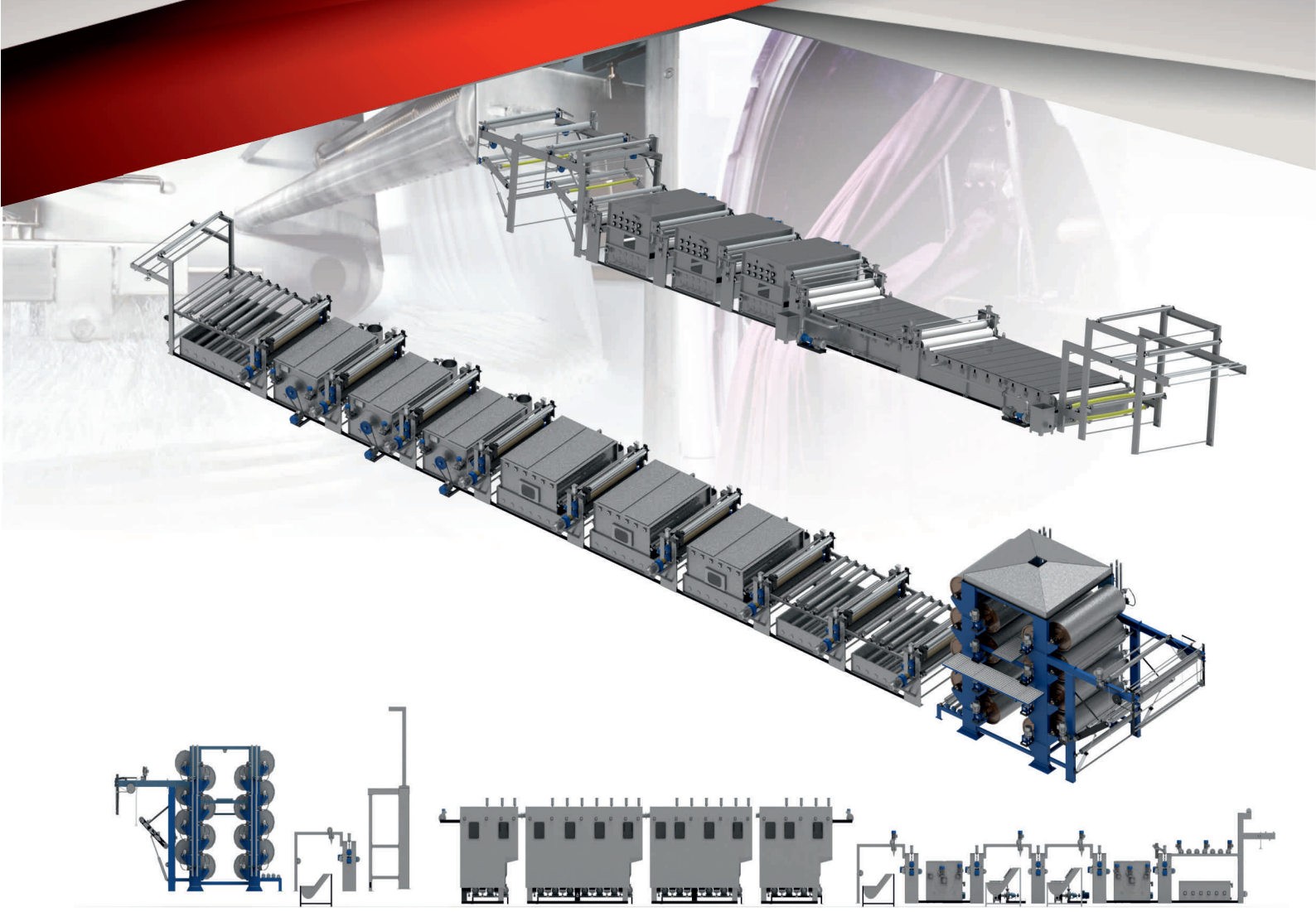

# TEXTILE PROCESSING MACHINERIES

A perfect  
**dyeing &  
processing**  
experience

**KRSNA GROUP** Textile machinery manufacturing is first generation family enterprises made a humble beginning in Mumbai apartment, by technocrat turned entrepreneur VJTT Mumbai graduate **MR. M.D. SHAH** (fellow Institute Manchester UK) Krsna Engineering works move in 1990 to present location of 2000 square yard plot 45, GIDC Naroda & Ahmadabad India. Well response from market for Krsna " younger brother P.D. Shah joined at initial stage followed with young techno savy family members helped Krsna expanded its activities & form new venture under leadership of **Mr. Chandresh Shah (Managing Director president of the Indian Textile Accessories & Machinery manufacture Association)** business & law graduate with help of uncle Mr. H.D. Shah electrical engineer Krsna Engimech PVT. LTD. B4, GIDC Phase-2, Naroda, Ahmedabad-328330.

Krsna as Group Completed 35 Years of Services to Textile Industries.

At present Krsna operates on 2000square yard plohas 20000 square feet fully mechanized workshop & 5000 square feet office blocks & 1500 fully mechanized workshop at new site.

The company is being managed by Mr. Chandresh shah with help of younger brother Priyank Shah Management graduate Australia return under guidance of uncle H.D. Shah & P.D. Shah.

Krsna group being make in India Company equip with excellent design AutoCAD software with 2 full time design engineers.

The work force of 8 qualified engineers

10 skills & 15 semi skill & 5 unskilled workers

Under the new venture at Krsna Engimech Private Limited Intent to develop energy saving environ friendly continuous tensionless washing ranges bleaching ranges for hosiery / terry towel woven fabric 1st time in India.

Water Consumption On Normal Washing Range is 50-60 liter Per Kg of Fabric Krsna Design Bring It Down to 20-25 Liter Per Kg of Fabric & While Is In Multipurpose Rope CBR Krs flow Water Consumption Will Be 10-15 Liter Water / Kilo of Fabric From Gray To White.

#### MANUFACTURING PROGRAMME OF KRSNA GROUP

- Krsna an Innovator Of Dyeing Technology Introduced 1st Time In India Soft / over Flow Dyeing Machines.
- 5 To 7 Soft Flow Dyeing Machines Fully Automatic Month Krsna Krantz Soft -flow Dyeing Machine.
- Krsna Continuous Open width Washing Ranges For knit Fabric & Woven
- Krsna open cum rope washing Range.
- Krsflow Continuous Rope Washing 86 Bleaching Range 1st Time In India
- Tumble Dryers For Woven & Knit Terry Towel
- Merceriser Mini & Regular.
- 

#### KRSNA GROUP CONCEPT TO REALITY

- Krsna With Its Zeal To Protect Environment Always Tried To Design Machinerries To Save Water Chemical Energy.
- Krsna Range Of Soft-flo W & Other Textile Processing Machinerries Fundamental Are Accuracy In Manufacturing Using Top Quality Materials.
- Krsna Ranges Of Machines Are Well Known For Reliability, Robust Construction & Ease In Operation.
- Krsna Gets 90% Repeat Order
- Krsna With Reinvent Obsession Could
- Introduce First Time In India
- Krsna Soft-flow Dyeing
- Krsflow Multipurpose Washing Cum Bleaching CBR
- Krsna Open Width Tensionless Vibro Drum Washer For Bio Wash & After Print Wash Of Knit Fabric.

#### **At Krsna We Adopted**

Lean manufacturing completeness system & 5s +

- Safety Rules ,
- Sort
- Straightens
- Shine
- Standardization

#### This system adoption helped in

- Mfg. Best Performing Machines
- Consistency In Quality
- Repeat Performance With Excellent Quality..
- Produce User Friendly Machines.
- Get 90% Repeat Order

**TODAY KRSNA IS NAME TO RECKON WITH KRSNA OPERATING ALL OVER INDIA & 23 COUNTRIES WORLDWIDE.**

Estd 1990

# KRSNA Group

CONCEPT TO REALITY

A perfect  
**dyeing &  
processing**  
experience

## KRSFLOW CONTINUOUS TENSIONLESS OPEN / ROPE WASHING & BLEACHING RANGE

1<sup>st</sup> time in INDIA

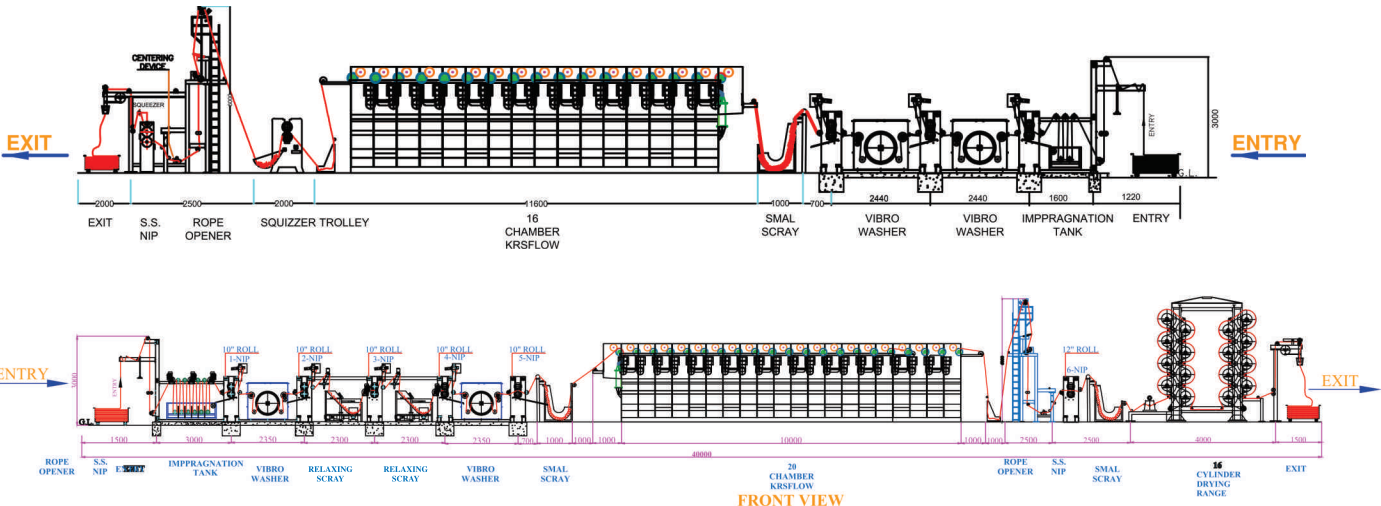
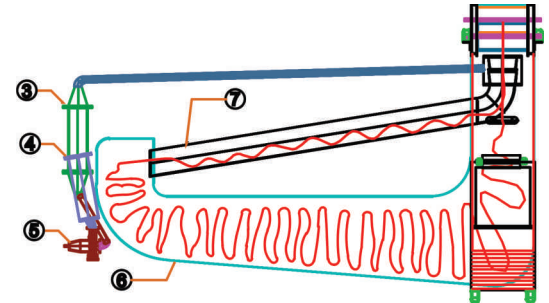
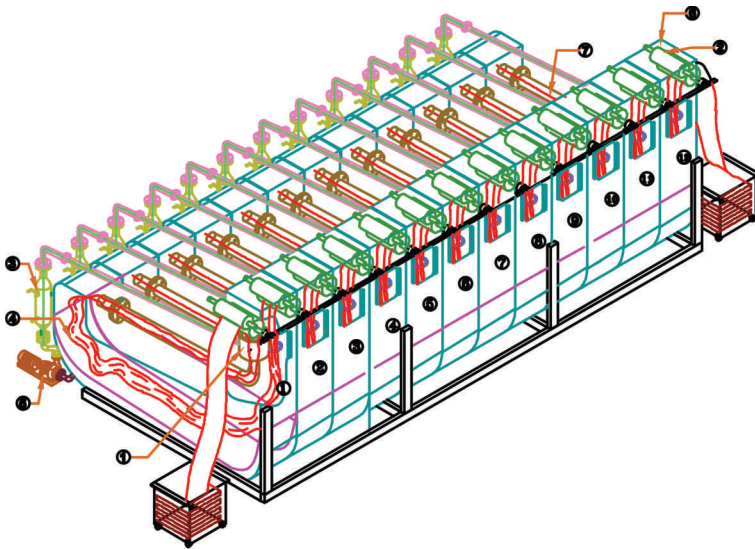
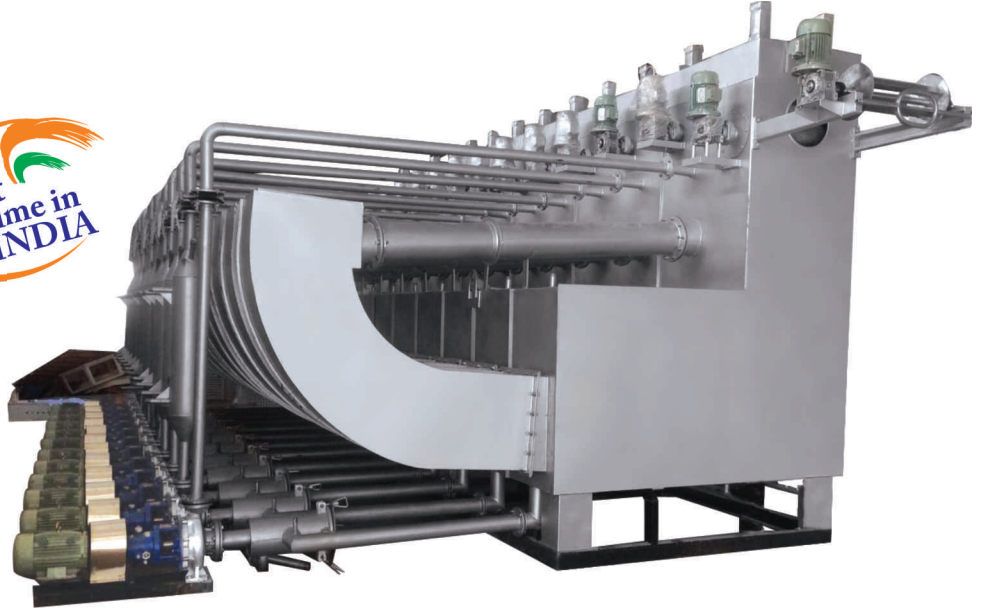

## KRSNA CHAINLESS CONTINUOUS MERCERISER

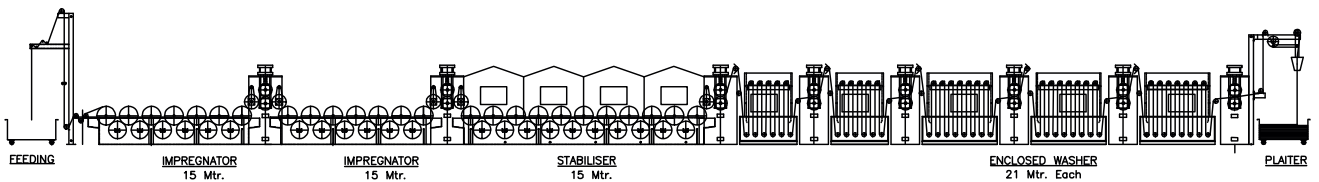
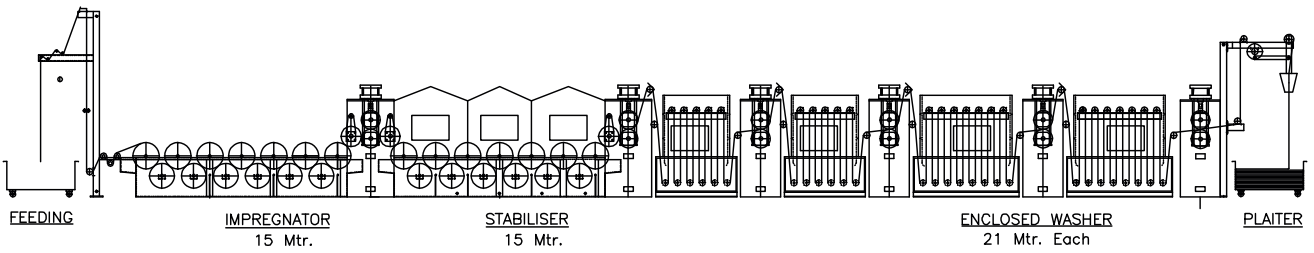
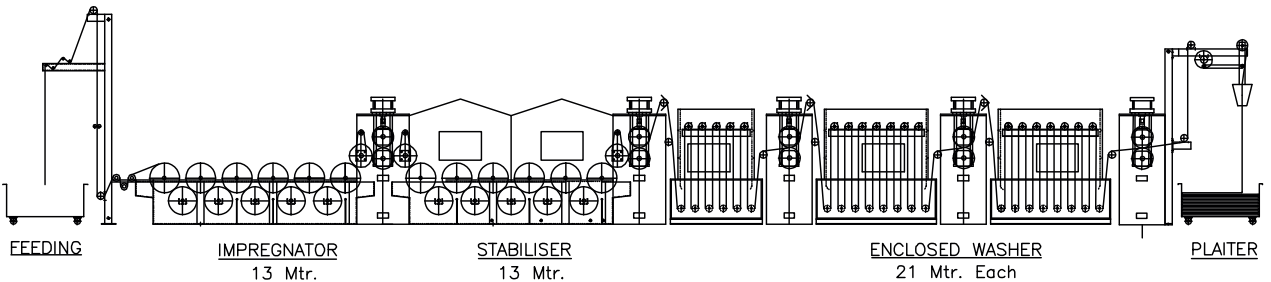
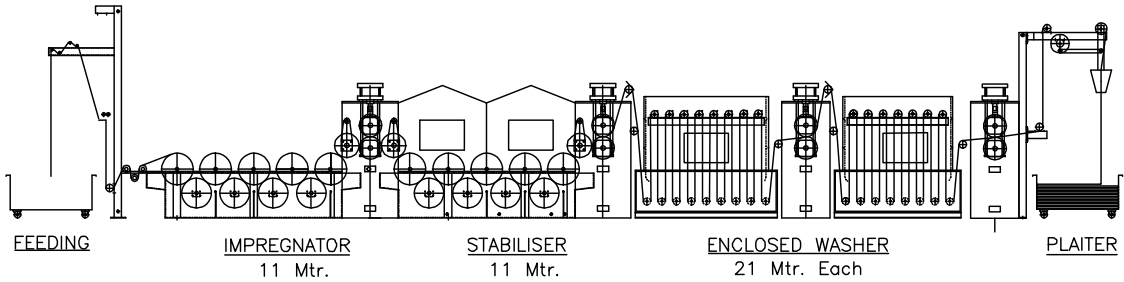
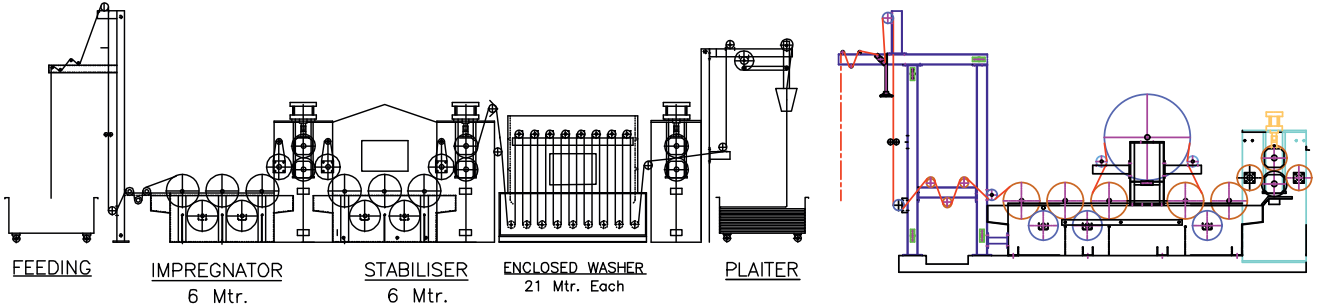

**KRSNA CHAINLESS CONTINUOUS MERCERISER**

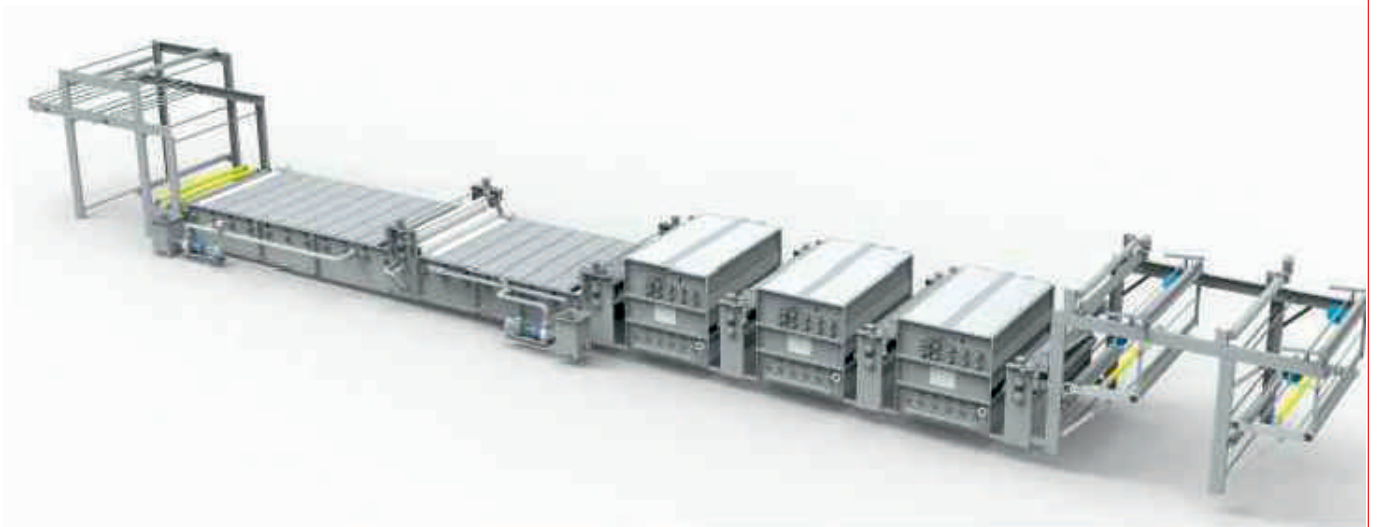
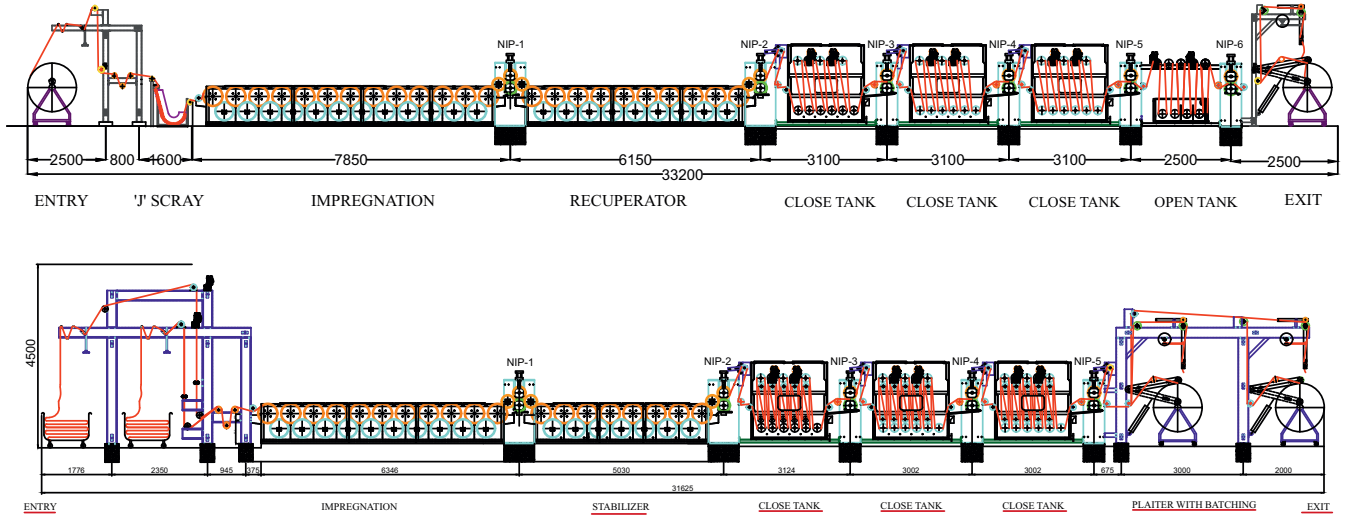

**KRSNA CONTINUOUS DESIZING & WASHING RANGE**

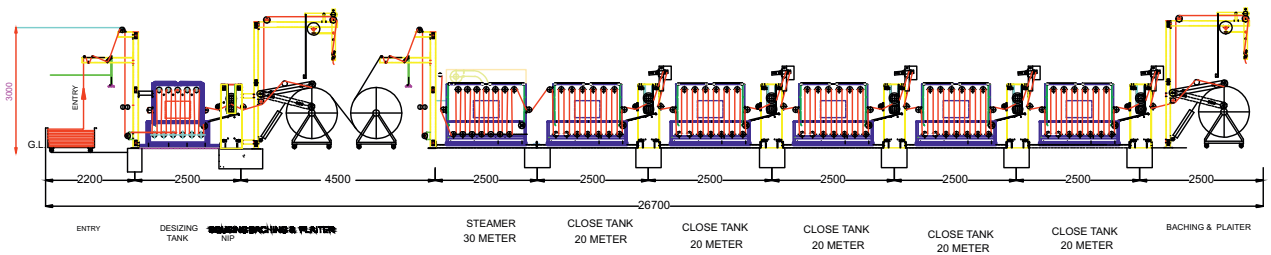

Estd 1990

# KRSNA Group

CONCEPT TO REALITY

A perfect  
**dyeing &  
processing**  
experience

## KRSNA OPEN WIDTH WASHING RANGE WITH MULTI CYLINDER DRYING RANGE

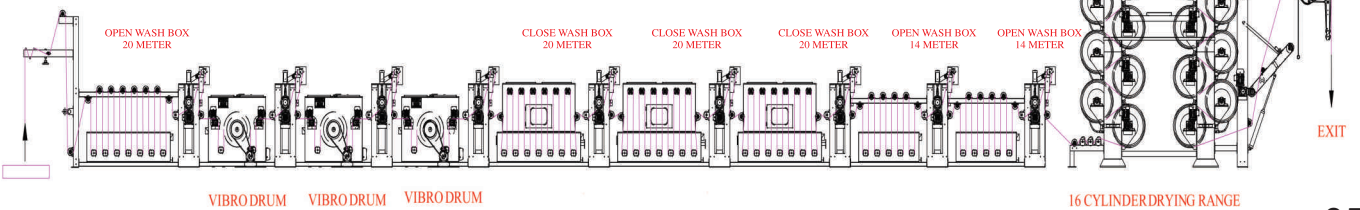
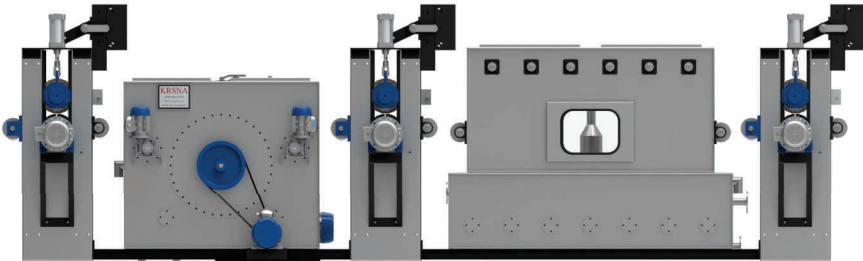
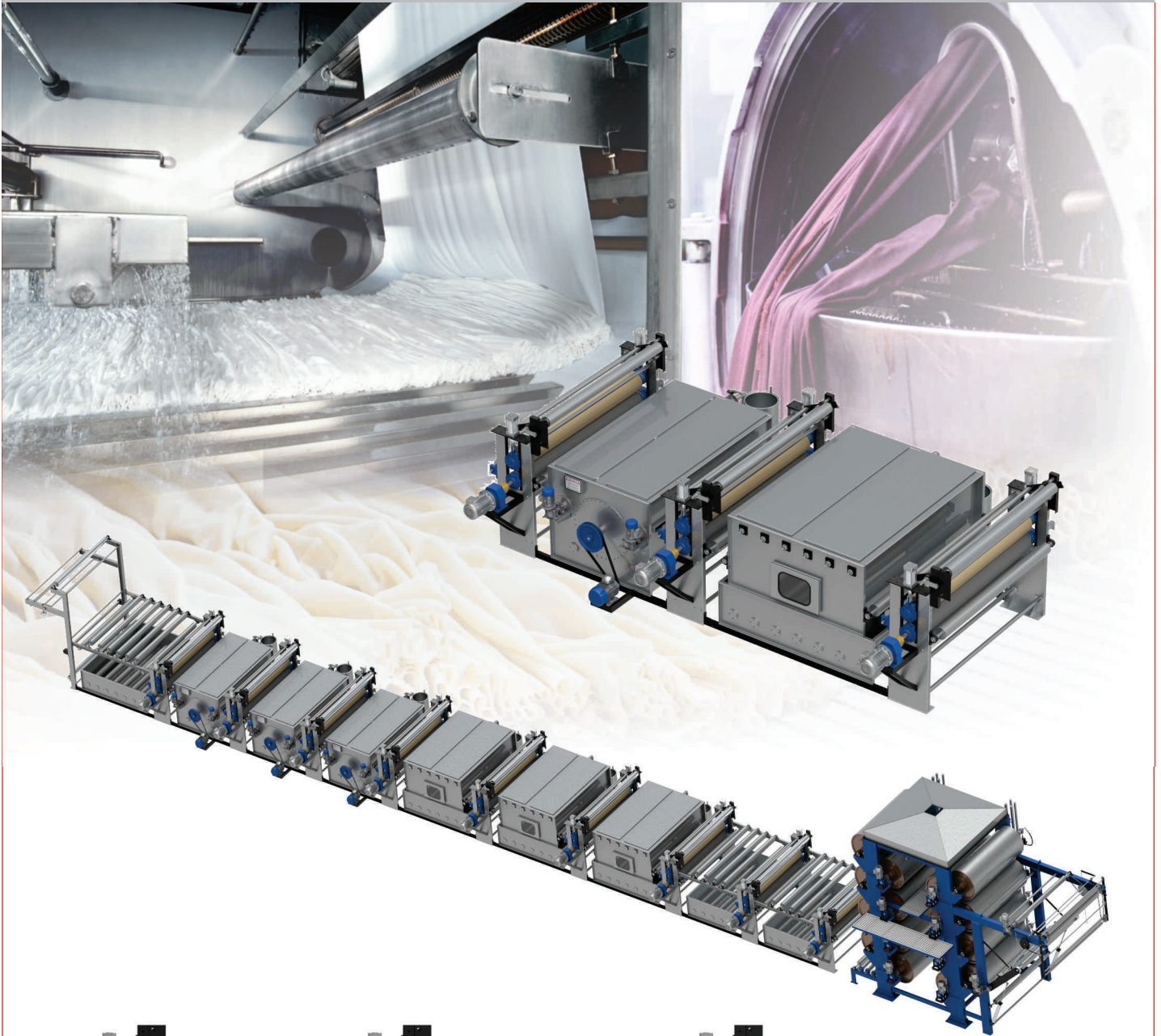

VIBRO DRUM VIBRO DRUM VIBRO DRUM

16 CYLINDER DRYING RANGE

**KRSNA OPEN WIDTH CONTINUOUS WASHING RANGE**

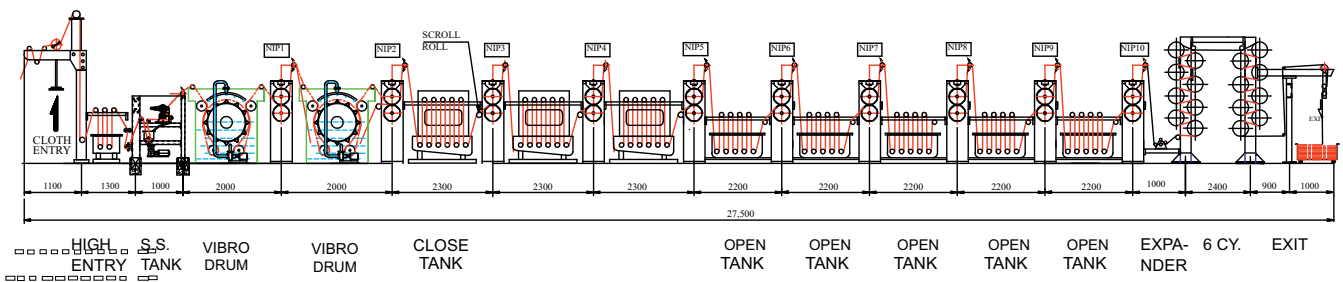
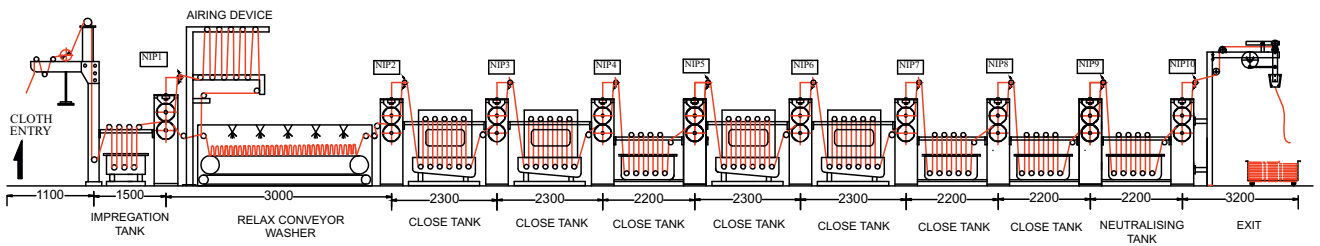
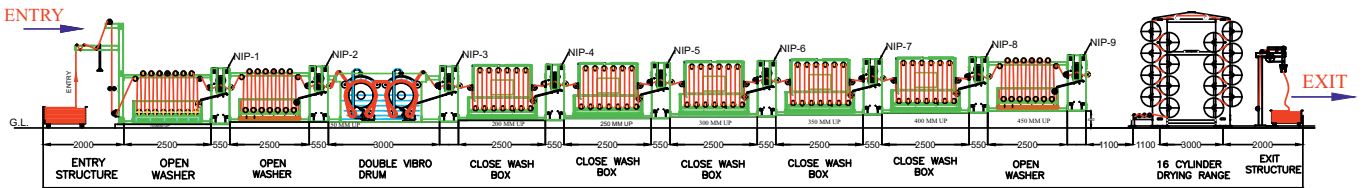
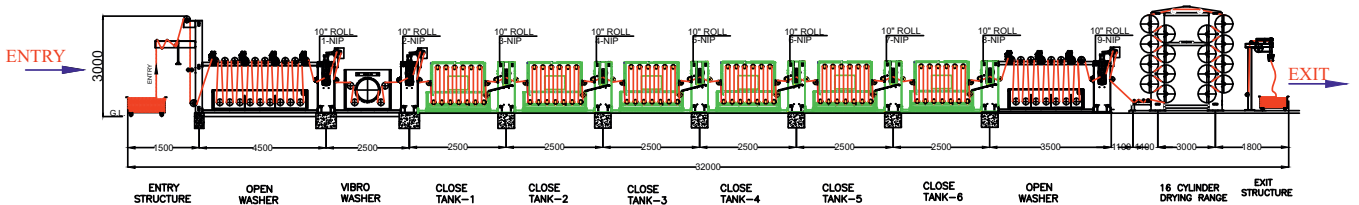
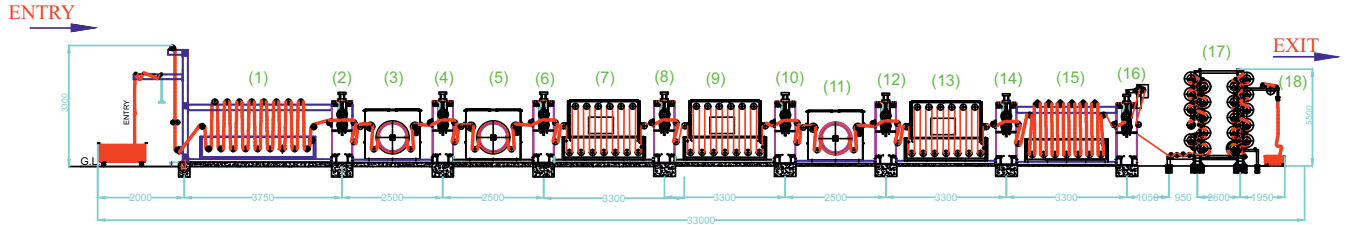

## KRSNA CONTINUOUS TENSIONLESS DRUM WASHER

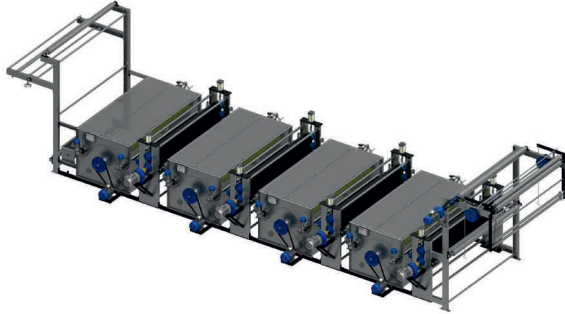

## KRSNA TENSIONLESS VIBRO DRUM

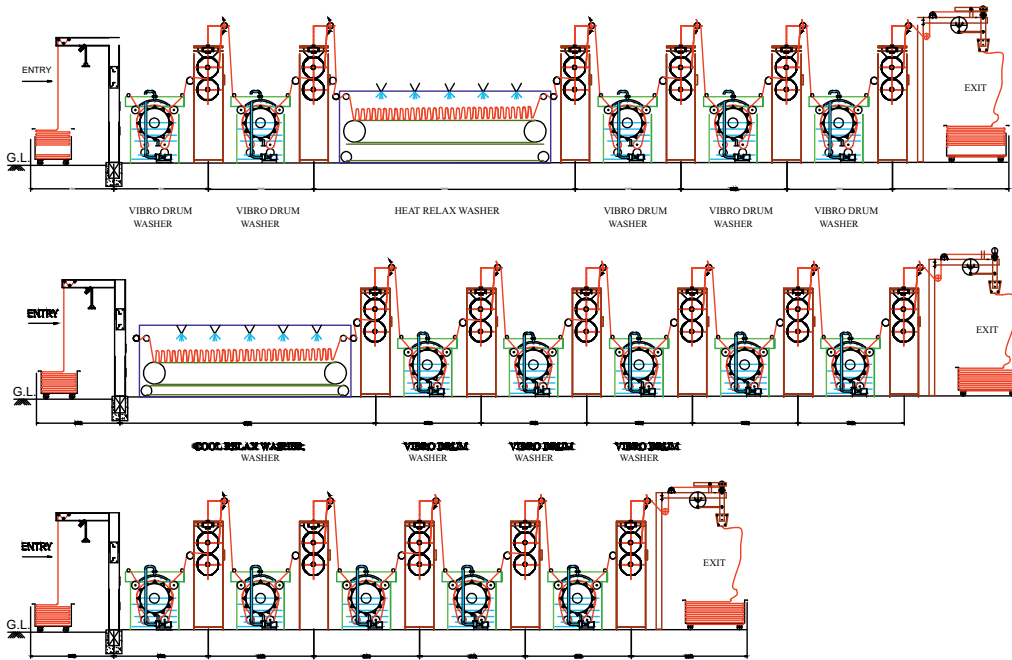

## KRSNA TENSIONLESS MINI WASHER

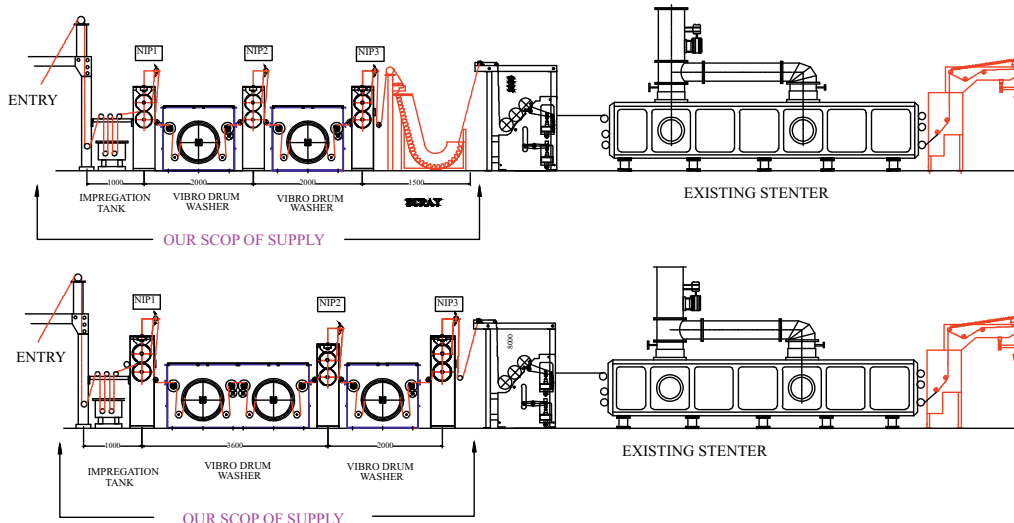

## KRSNA OPEN - ROPE WASHING RANGE

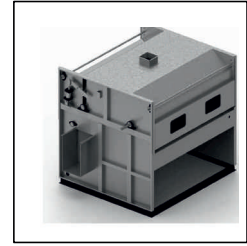
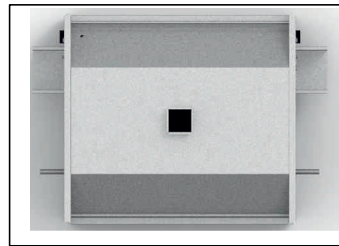
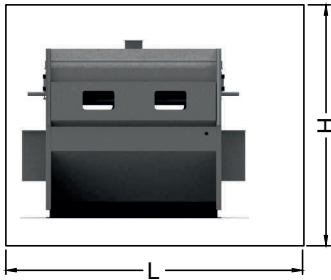
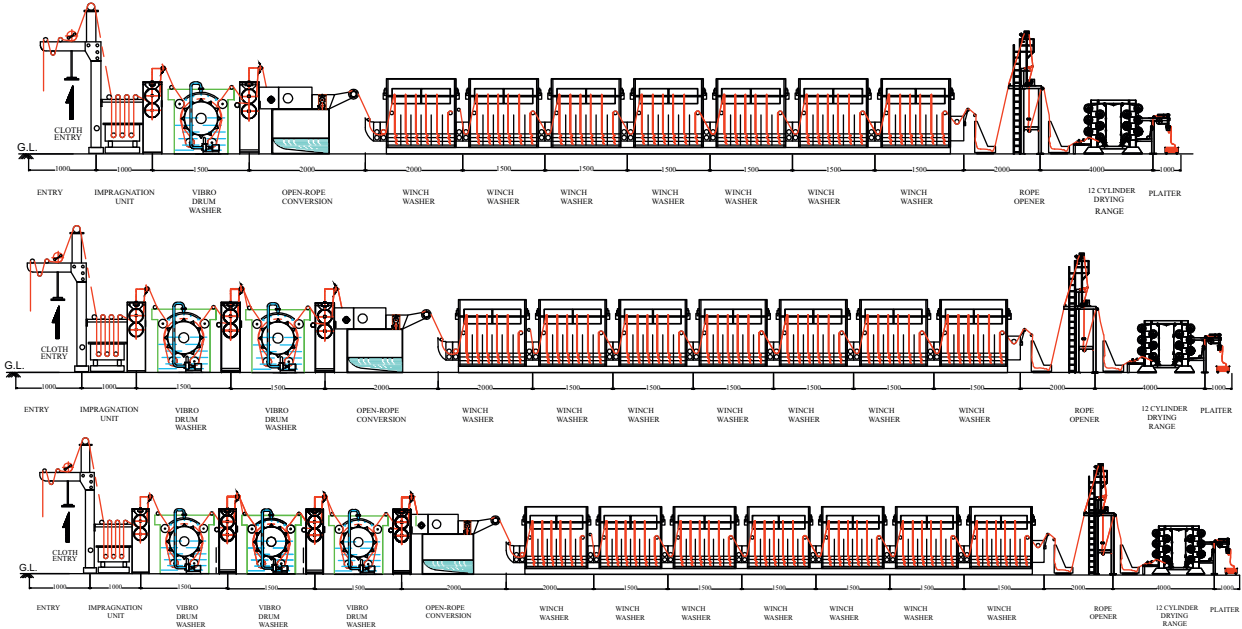

## KRSNA JIGGER DYEING MACHINE

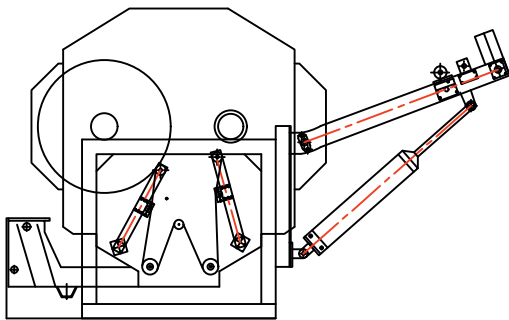

## KRSNA OPEN - CLOSE S.S WINCH

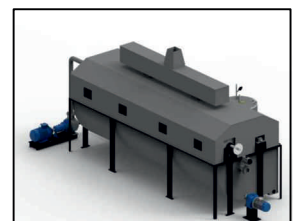
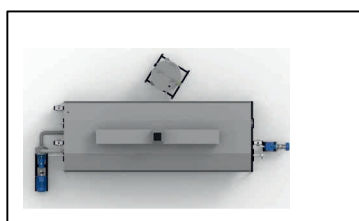
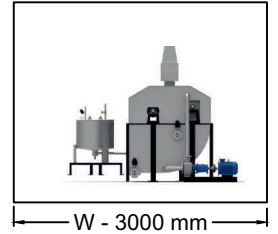
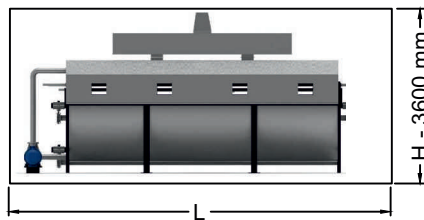

## KRSNA VERTICAL DRYING RANGE CYCLINDER

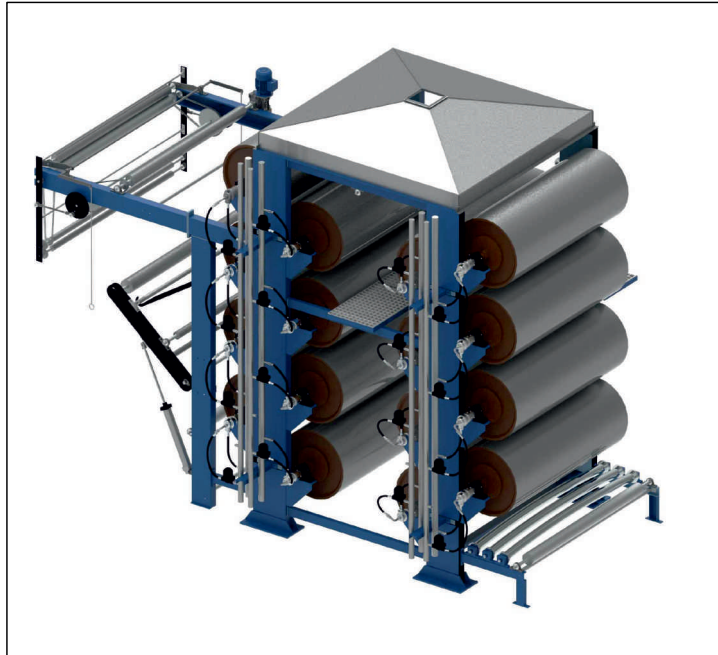

## KRSNA 2/3 BOWL PADDING MANGLE

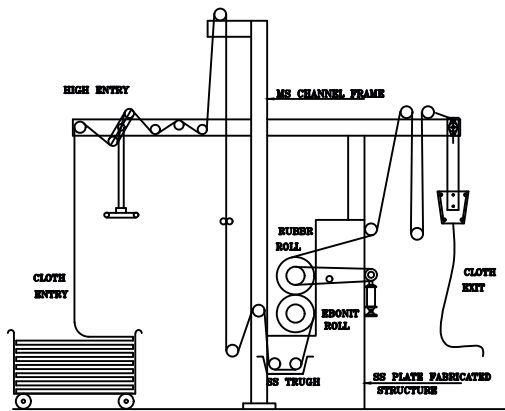

ENTRY

2-BPM

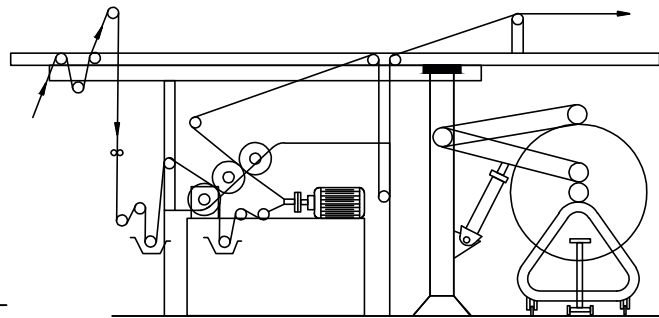

3-BPM

## KRSNA OPEN WIDTH VACCUM EXTRACTOR

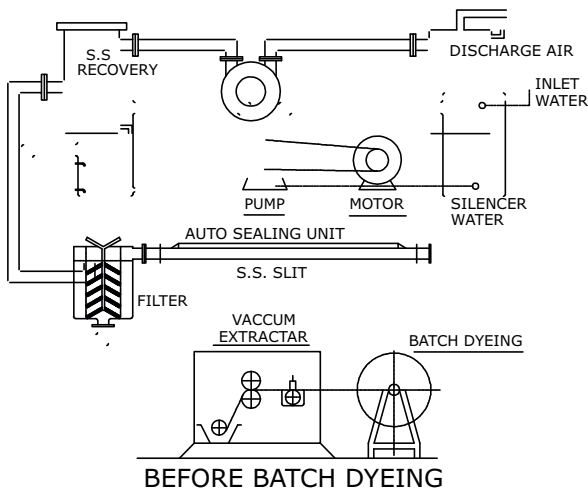

BEFORE BATCH DYEING

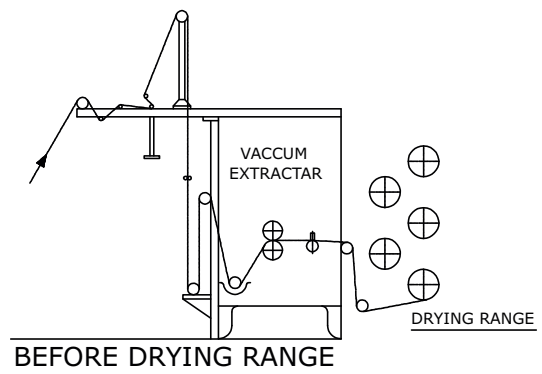

BEFORE DRYING RANGE

## KRSNA ROPE FABRIC OPENING DEVICE

OUR SCOPE  
OF SUPPLY

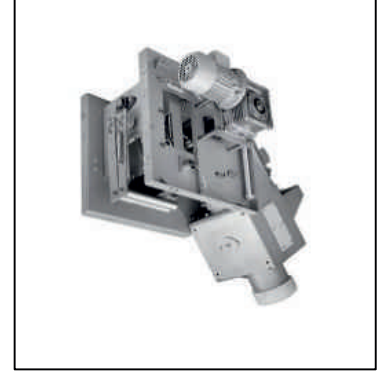
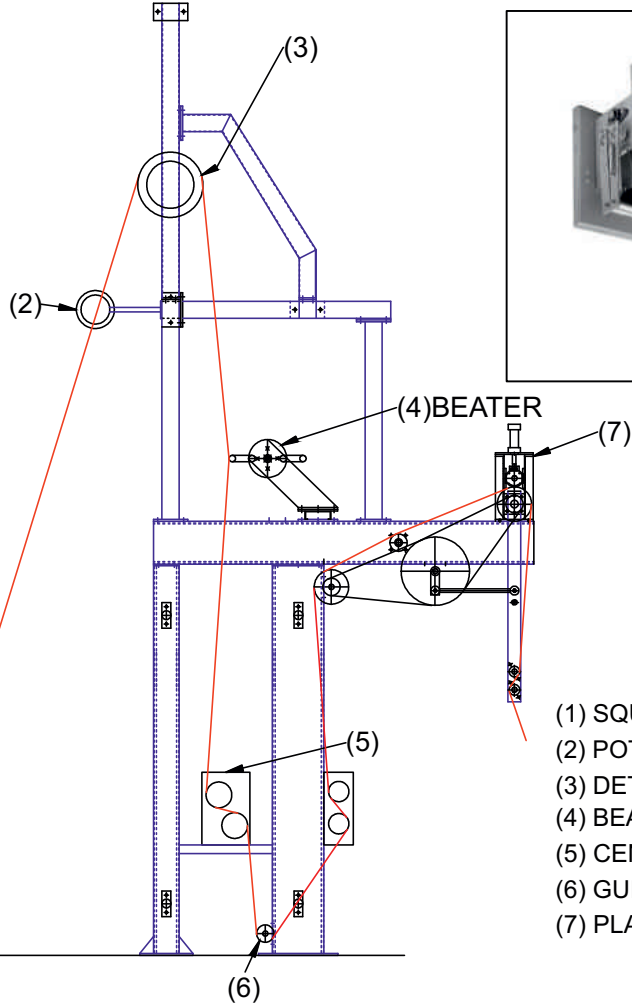
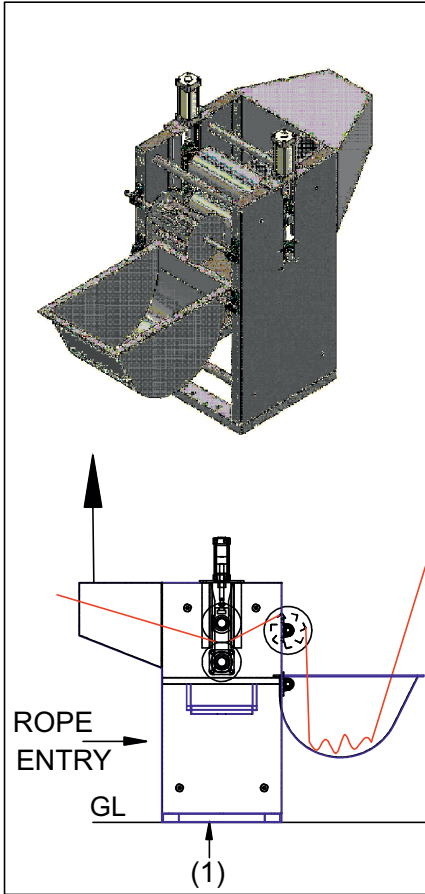

- (1) SQUEEZER
- (2) POT-EYE
- (3) DETWISTER
- (4) BEATER
- (5) CENTERING DEVICE UNIT
- (6) GUIDE ROLL
- (7) PLATING DEVICE UNIT

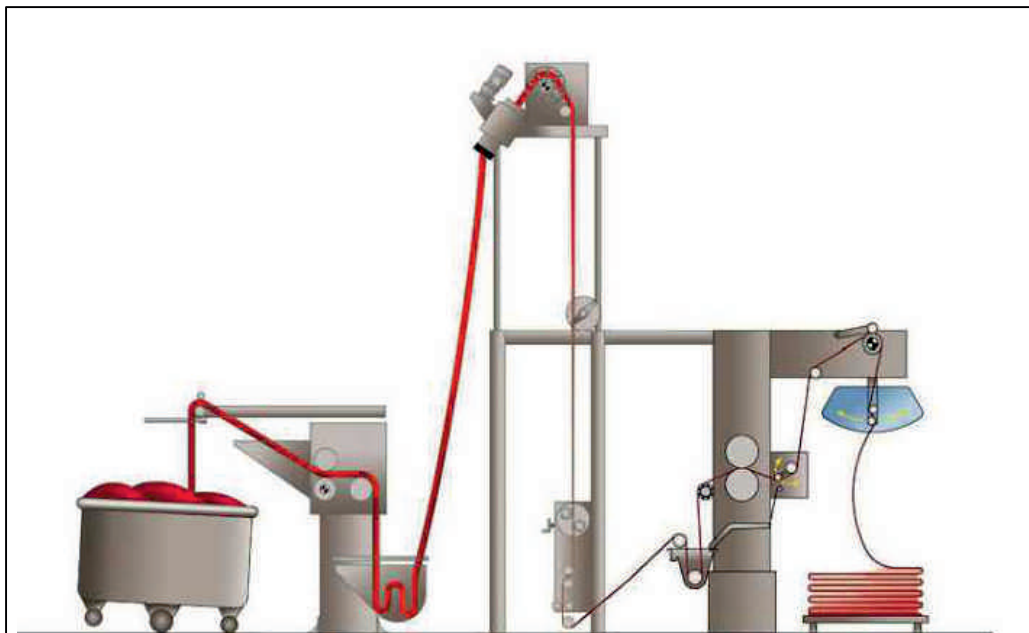

Estd 1990

# KRSNA Group

CONCEPT TO REALITY

## KRSNA SOFT FLOW FAMILY

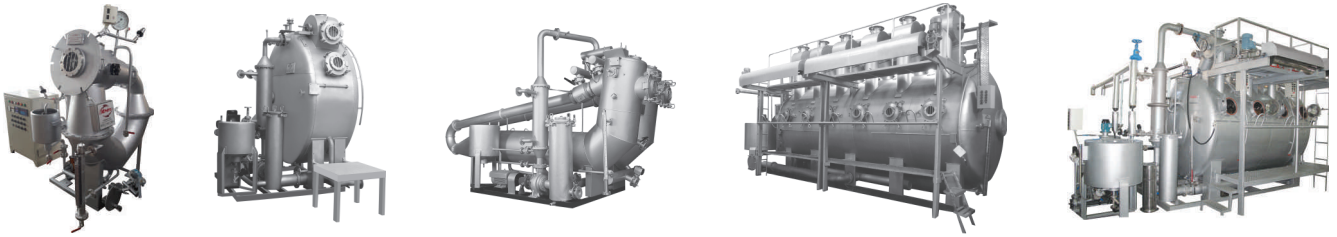

## AQUA - FINISH



# KRSNA ENGINEERING WORKS

HEAD OFFICE :

45, G.I.D.C. Phase-1, Naroda, Ahmedabad 382 330 (India)

Tel : + 91 79 22823093

Mob : + 91 98250 96234 / 90999 30017

Email : [chandreshshah09@gmail.com](mailto:chandreshshah09@gmail.com) / [sales@krsnagroup.in](mailto:sales@krsnagroup.in) / [md@krsnagroup.in](mailto:md@krsnagroup.in)

Website : [www.krsnagroup.in](http://www.krsnagroup.in)